

Zylinderbefestigung

– nachschmierbarer Gelenkkopf mit Gewinde –

Material: Stahl C45

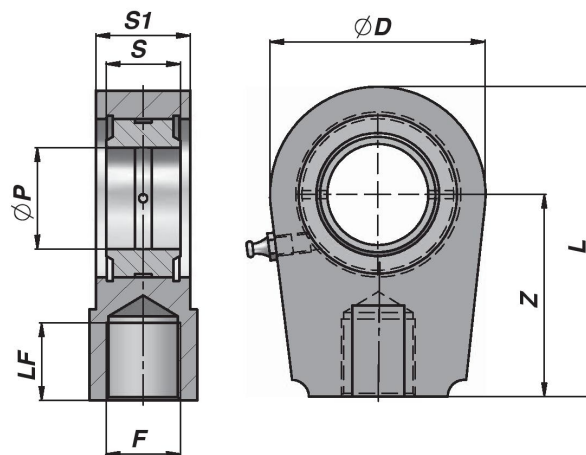

Bestell-Nr.	Typ	ØP	ØD	Z	S	S1	L	LF	F	FC (t)	Kg
116-302-01000	Gelenkauge TAPR020N	20	56	50	16	19	80	17	M 16 x 1,5	3,00	0,45
116-302-01050	Gelenkauge TAPR025N	25	56	50	20	23	80	17	M 16 x 1,5	4,80	0,49
116-302-01100	Gelenkauge TAPR030N	30	64	60	22	28	94	23	M 22 x 1,5	6,20	0,76
116-302-01150	Gelenkauge TAPR035N	35	78	70	25	30	112	29	M 28 x 1,5	8,00	1,26
116-302-01200	Gelenkauge TAPR040N	40	94	85	28	35	135	36	M 35 x 1,5	10,00	2,15
116-302-01250	Gelenkauge TAPR050N	50	116	105	35	40	168	46	M 45 x 1,5	15,60	3,80
116-302-01300	Gelenkauge TAPR060N	60	130	130	44	50	200	59	M 58 x 1,5	24,50	6,20
116-302-01350	Gelenkauge TAPR070N	70	154	150	49	55	232	66	M 65 x 1,5	31,50	9,83
116-302-01400	Gelenkauge TAPR080N	80	176	170	55	60	265	81	M 80 x 2,0	40,00	13,97

FC: maximale dynamische Last (Tonne)